



WOOD INDUSTRY

Speed Stacker Gantry Robot



JOULIN
A brand by Piab Group

See the video
of Speed Stacker



SPEED STACKER



The perfect tool to meet the need for wide area stacking!

- ✓ 400 or 600kg lifting capacity
- ✓ Lifting movements up to 1 m/s
- ✓ Traversing movements up to 2 m/s
- ✓ Stacking/sorting over a large area
- ✓ Instant picking and release of the boards
- ✓ Warm air backflow for extreme and cold environments
- ✓ Easy and low maintenance



360° Rotation

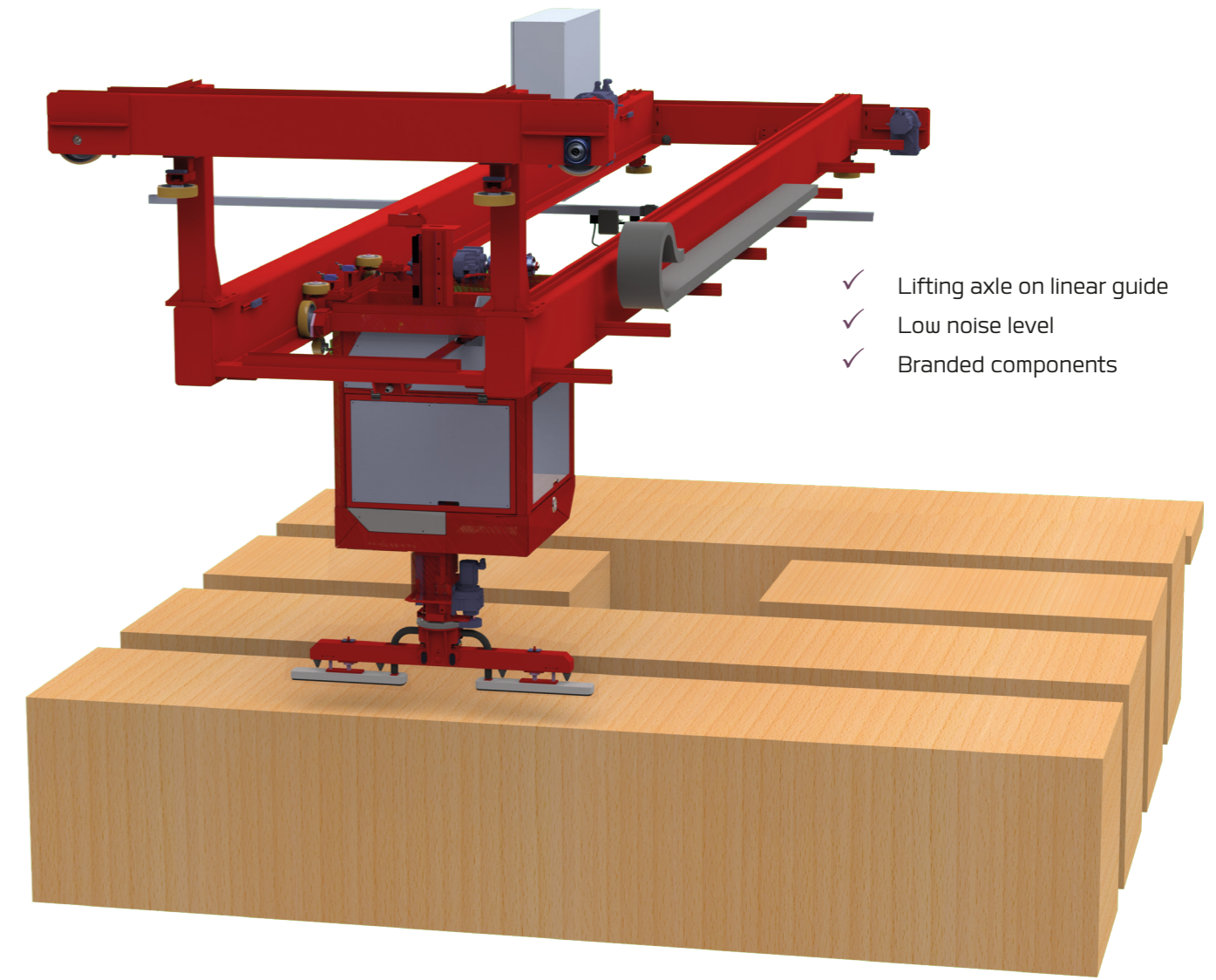
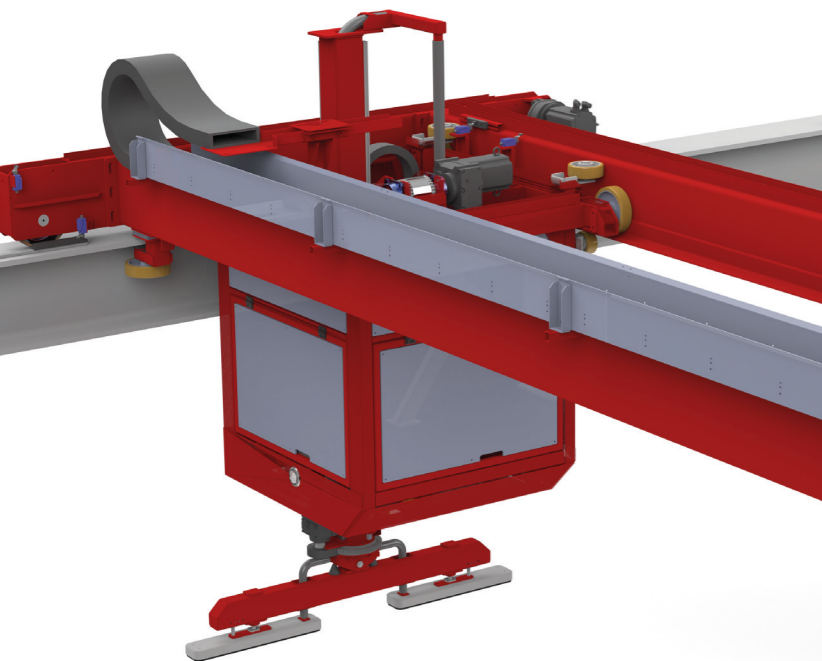

- ✓ Lifting axle on linear guide
- ✓ Low noise level
- ✓ Branded components

High speed stacking and sorting

Technical Data

- 4 axis (lifting, cross and length movements, 360° rotation)
- SEW CM3C Servomotors and Gen C inverters
- Transmission with Timing Belt and Polyurethane wheels
- Radiocommand with EtherCat protocol
- Lifting movement with linear guiding system
- On-board electrical control box
- Filtering system for wet and dusty environments

Characteristics / Standards	Speed Stacker 400	Speed Stacker 600
Structure	standard	reinforced
Length of boards	7000mm	10000mm
Weight of boards	400kg	600kg
Height of stack	1600 to 2000mm	
Gripper dimensions	2 grippers 100x650mm	2 grippers 100x900mm
Lifting Axis	ball-bearing guide	roller guide
Filter rating	5 µ	
Air Filter	option	
Maintenance access	4 doors with gas springs	
Lifting Servo motor power rating	7,5kw	11kw
Traversing Servo motor power rating	5,5kw	7,5kw
High vacuum level blower	-700mBar	
Radio control	IP65 protection rating	

Ergonomic and compact Radio-Command

SCREEN

Backlit screen with feedback

BUTTONS

Navigation and on/off buttons



Bidirectional
radio link

SWITCHES

Multiple possibilities of configurable functions

JOYSTICKS

Joysticks for stacker movements



EMERGENCY STOP

Safety Mushroom Stop
SIL 3 - PL E

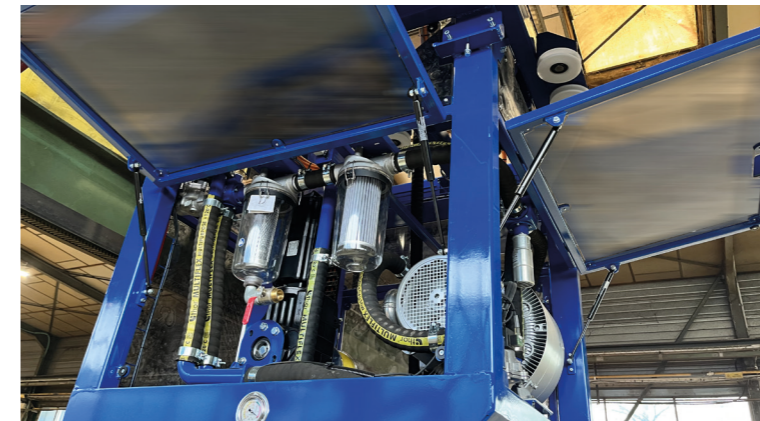
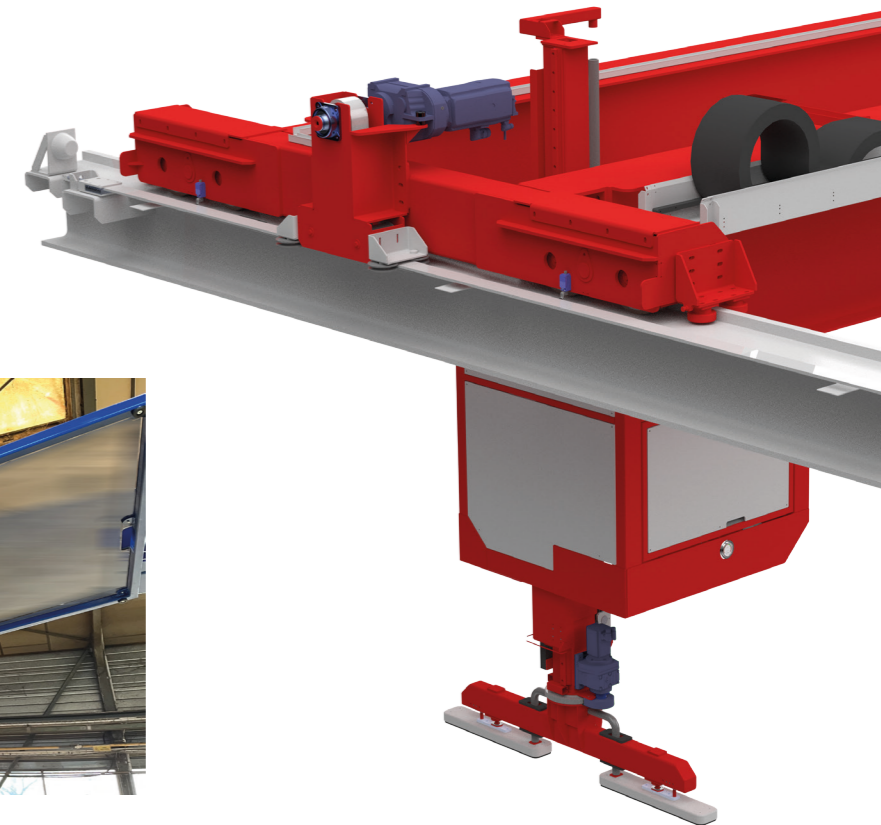
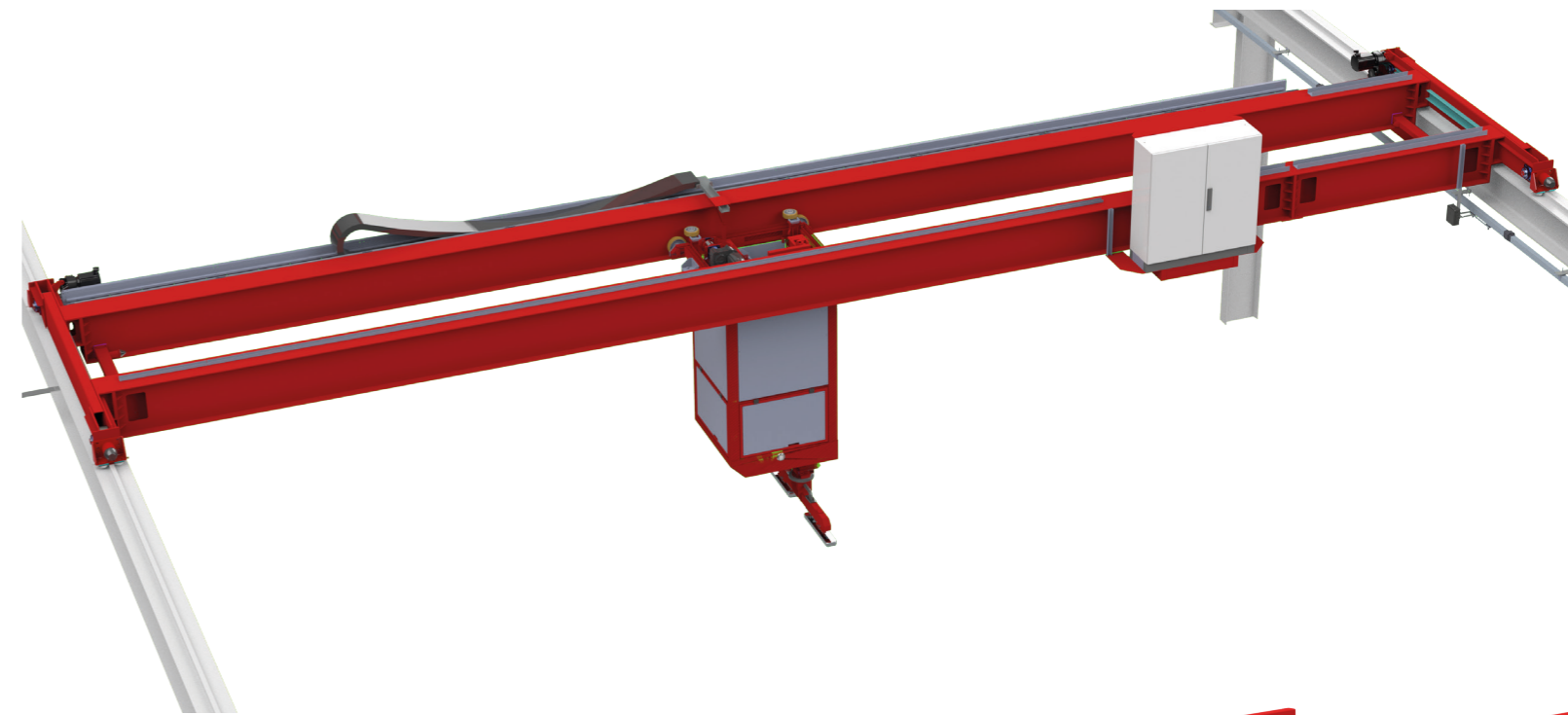

4 doors with springs for easy maintenance



Filtering system for wet and dusty environments



Polyurethane wheels



SEW Gen C inverters

Examples of installations

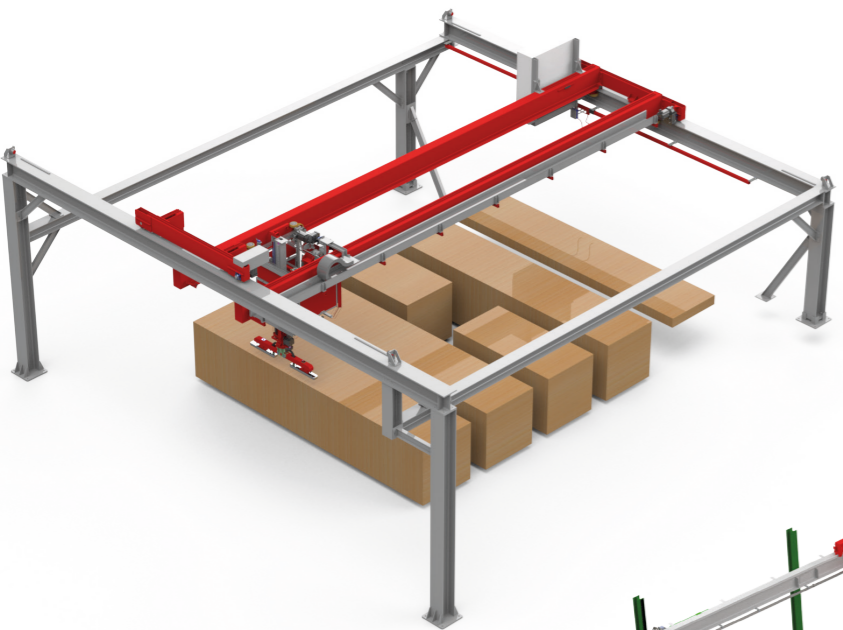

Configuration A Fixed framework (gooseneck possible)

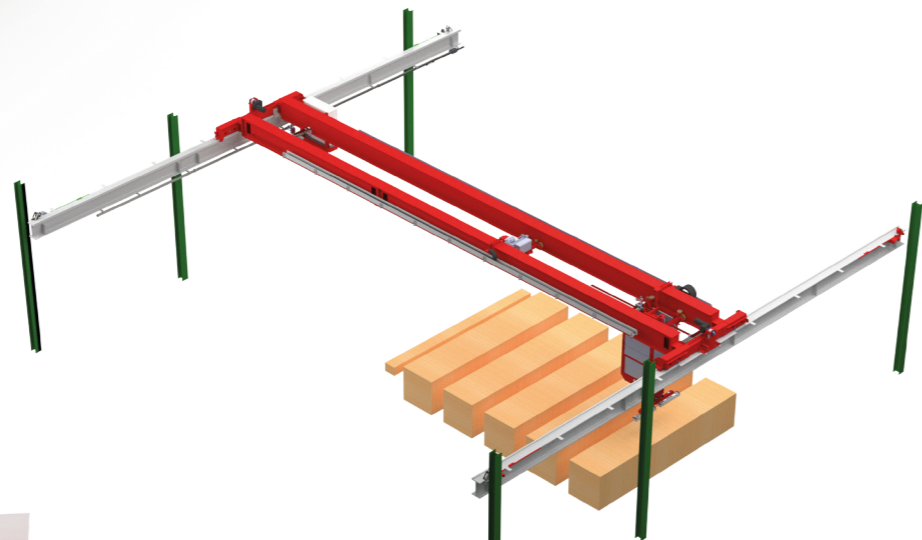

Configuration B Rolling tracks on building columns

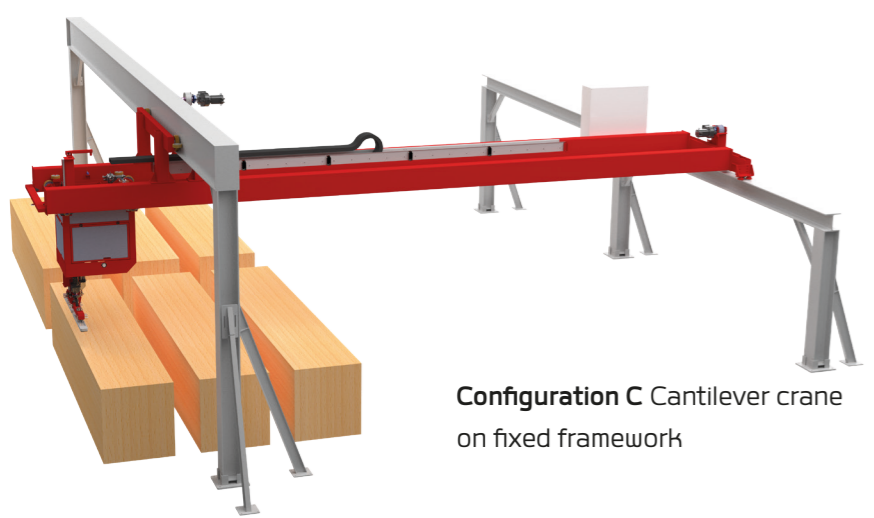

Configuration C Cantilever crane on fixed framework

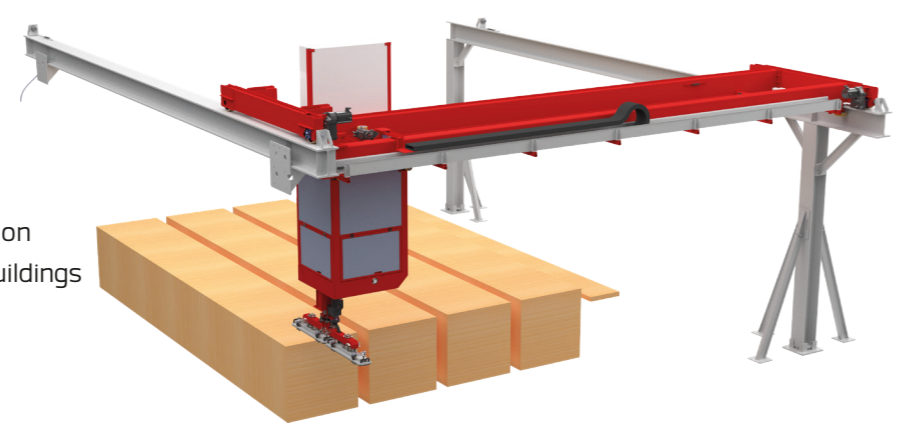

Configuration D Crane on fixed framework and buildings

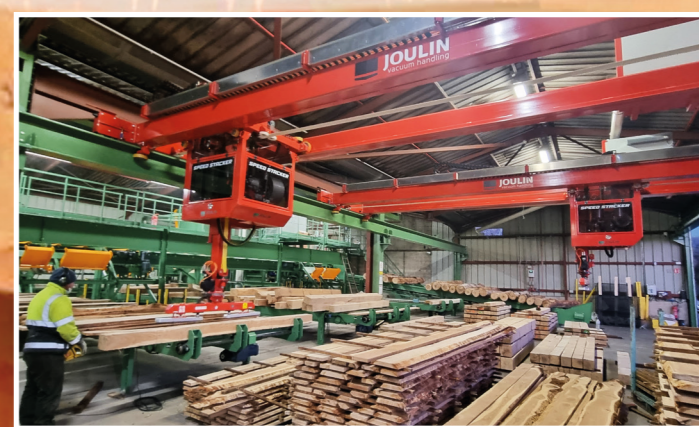

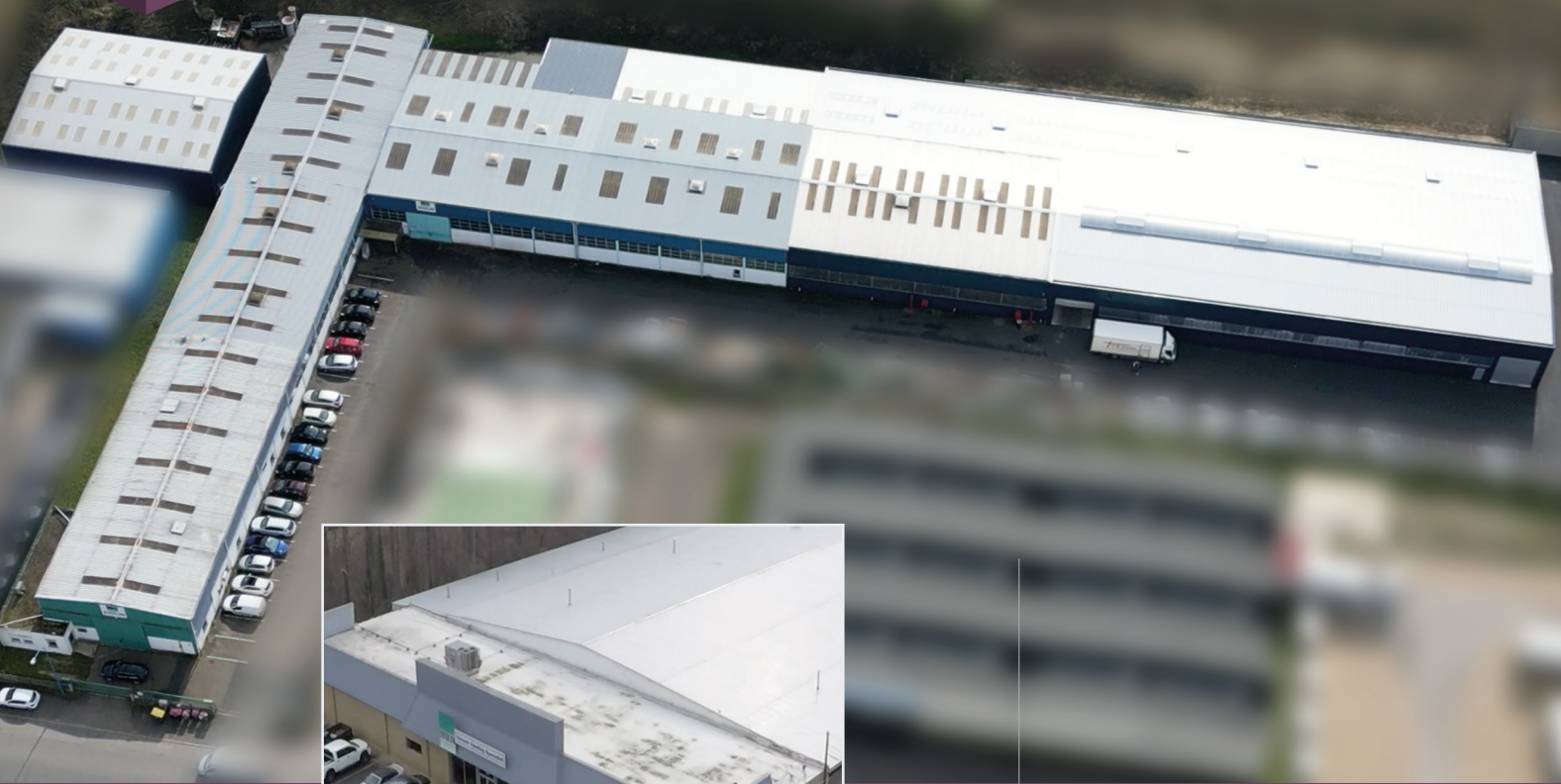

France

17 avenue des Grenots
F-91150 ETAMPES

Tél. +33 (0)1 69 92 16 16
Fax +33 (0)1 64 94 21 35

USA

2551 Hwy 70 SW - HICKORY
NC-28602

Phone : + (1) 828 327 2290
Fax : + (1) 828 327 8678



Contact us



JOULIN

A brand by Piab Group

contact : wood@joulin.com

www.joulin.com