

# Foam Vacuum Gripper

# Questionnaire



Fax Europe : +33 (0)1 64 94 21 35  
 Fax USA : +(001)828 327 8678  
 E-mail : grippers@joulin.com

*From*

Company : \_\_\_\_\_  
 Name : \_\_\_\_\_  
 Address : \_\_\_\_\_  
 City/State/Country : \_\_\_\_\_  
 Phone : \_\_\_\_\_  
 Fax : \_\_\_\_\_  
 E-mail : \_\_\_\_\_

*Please answer the following questions and we will select the best vacuum gripper suited to your needs. Fill the questionnaire and send it via fax or E-mail.*

Describe product(s) to be handled : \_\_\_\_\_

- |        |             |            |                                   |                   |
|--------|-------------|------------|-----------------------------------|-------------------|
| Single | Round       | Smooth     | Number of products/layers : _____ |                   |
| Layers | Oval        | Rough      | Twisted : No                      | Yes : _____ mm/in |
|        | Square      | Grooves    | Slip sheets : No                  | Yes               |
|        | Rectangular | Oily       | Pallets : No                      | Yes               |
|        |             | Wet        |                                   |                   |
|        |             | Porous     |                                   |                   |
|        |             | Non porous |                                   |                   |

Dimensions :

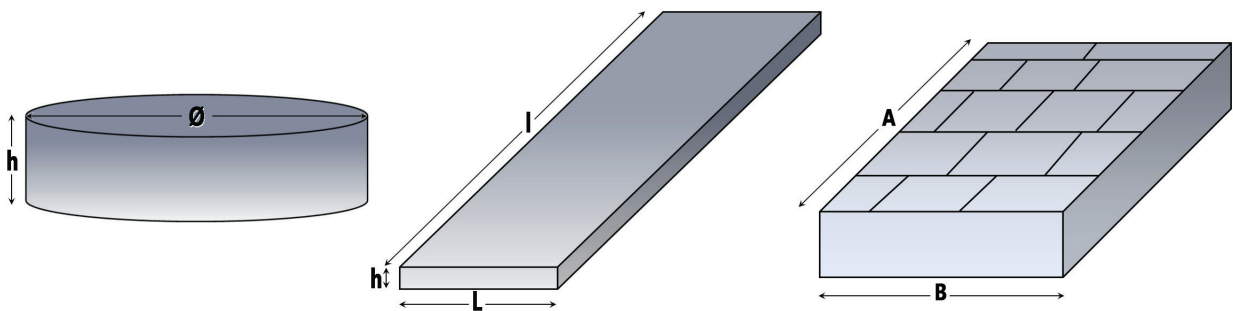

|      | Ø | h | L | l | A | B | Weight |
|------|---|---|---|---|---|---|--------|
| Mini |   |   |   |   |   |   |        |
| Maxi |   |   |   |   |   |   |        |

Remarks about the products : \_\_\_\_\_  
 \_\_\_\_\_  
 \_\_\_\_\_  
 \_\_\_\_\_  
 \_\_\_\_\_

# Foam Vacuum Gripper

## Application :

Description of the application : \_\_\_\_\_  
\_\_\_\_\_  
\_\_\_\_\_  
\_\_\_\_\_  
\_\_\_\_\_

Number of cycles per minute : \_\_\_\_\_

Product acceleration : \_\_\_\_\_

Maximum robot capacity : \_\_\_\_\_

Type of handler :      Gantry              Robot

Attachment needed :      No              Yes

Remarks about the application : \_\_\_\_\_  
\_\_\_\_\_  
\_\_\_\_\_  
\_\_\_\_\_

All our grippers are sized using Joulin's Griptech™ software benefiting from over 50 years of Research and experience with foam grippers

---

Notes : \_\_\_\_\_  
\_\_\_\_\_  
\_\_\_\_\_  
\_\_\_\_\_  
\_\_\_\_\_  
\_\_\_\_\_  
\_\_\_\_\_  
\_\_\_\_\_  
\_\_\_\_\_

---

